MultiModem™ GSM/GPRS
External Wireless Modem
(Data/Fax/Voice)
MTCBA-G-F1
MTCBA-G-F2

UserGuide



**User Guide for MultiModem GSM/GPRS
External Data/Fax/Voice Wireless Modem
Models MTCBA-G-F1 & MTCBA-G-F2**

P/N 82001220, Revision A

Copyright © 2003 by Multi-Tech Systems, Inc.

All rights reserved. This publication may not be reproduced, in whole or in part, without prior expressed written permission from Multi-Tech Systems, Inc.

Multi-Tech Systems, Inc. makes no representation or warranties with respect to the contents hereof and specifically disclaims any implied warranties of merchantability or fitness for any particular purpose. Furthermore, Multi-Tech Systems, Inc. reserves the right to revise this publication and to make changes from time to time in the content hereof without obligation of Multi-Tech Systems, Inc., to notify any person or organization of such revisions or changes.

Revision	Date	Description
A	5/01/03	Initial Release, Rev A.

Multi-Tech, MultiMobile and the Multi-Tech logo are trademarks of Multi-Tech Systems, Inc. Windows is a registered trademarks of Microsoft in the U.S. and other countries. Other trademarks and trade names mentioned in this publication belong to their respective owners.

<p>Call ARC Electronics 800-926-0226 512-864-0756 Ex 42</p>

Contents

PRODUCT DESCRIPTION	5
<i>Package Contents</i>	6
<i>Interfaces</i>	6
<i>Parts to be Supplied by Wireless Service Provider</i>	7
<i>Parts to be Supplied by End User</i>	7
<i>Radio Characteristics</i>	8
<i>Accessory Kit</i>	9
<i>AT Command Info</i>	10
<i>Phone Number for the Wireless Modem</i>	10
<i>Network Access</i>	10
<i>Features</i>	12
APPLICATION OVERVIEW	13
<i>Application Types</i>	13
<i>Benefits/Features in Applications</i>	15
<i>Functions – GSM Modes</i>	18
SPECIFICATIONS	19
<i>General Specifications</i>	19
<i>Electrical Characteristics</i>	20
Input/output electrical characteristics for external connections	21
Input/output electrical characteristics (cont'd)	22
<i>LED Indicators</i>	23
<i>RS232 15-Pin Connector Pinout</i>	24
GETTING STARTED WITH YOUR WIRELESS MULTIMODEM	25
<i>Mechanical Mounting</i>	25

<i>Electrical Installation & Configuration</i>	28
<i>Mobile Phonetools</i>	34
<i>Verifying signal strength</i>	35
<i>Verifying network registration</i>	36
<i>Testing the Configuration</i>	37
Testing the Configuration (continued)	38
Testing the Configuration (continued)	39
TRUBLESHOOTING	40
<i>Situation A: The modem does not answer through the serial link</i>	40
<i>Situation B: The modem always returns «Error» when trying to issue a communication</i>	42
<i>Situation C: The modem always returns «No carrier» when trying to issue a communication</i>	47
SAFETY	51
<i>General Safety</i>	51
<i>Vehicle Safety</i>	53
<i>Maintenance of GSM Modem</i>	53
<i>Your Responsibility</i>	54
WARRANTY & REPAIRS POLICIES	55
<i>Warranty</i>	55
<i>Repairs</i>	56
Repair Procedures for U.S. and Canadian Customers	56
Repair Procedures for International Customers (Outside U.S.A. and Canada)	58
Repair Procedures for International Distributors	59
WIRELESS MODEM REFERENCE INFO	60

Product Description

The Multi-Tech MultiModem GSM/GPRS is an external data/fax/voice wireless modem. It also supports mobile originated short message service (SMS) and mobile-terminated SMS. Designed for global use, it offers standards-based multi-band GSM/GPRS Class 10 performance. This ready-to-deploy, standalone modem allows developers to add wireless communication to products with a minimum of development time and expense. The MultiModem GSM/GPRS is based on industry-standard open interfaces, is fully type approved, and can be desktop or panel mounted.

Package Contents

- one modem
- two holding bridles (mounting brackets)
- one RS-232 15-to-9-pin cable
- one power supply cable with fuse
- one User Manual (this document)

Interfaces

The Wireless MultiModem has several interfaces:

- LED function indicating operating status
- External antenna (via SMA connector)
- Serial and control link (via 15 pins SUB D)
- Power supply (via 2.5mm miniature power jack)
- SIM card holder

Parts to be Supplied by Wireless Service Provider

- Subscriber Identity Module (SIM) configuration chip
The SIM contains information specific to your wireless account and its features.

Parts to be Supplied by End User

- mounting screws
(screw shaft diameter = .17" max.)
- antenna
The antenna used must be both of the correct frequency and of the style appropriate to the application.

Product Description

Radio Characteristics

	GSM 850	EGSM 900
Frequency RX	869 to 894 MHz	925 to 960 MHz
Frequency TX	824 to 849 MHz	880 to 915 MHz
RF Power Stand	2W at 12.5% duty cycle	2W at 12.5% duty cycle
Impedance	50 ohms	
VSWR	<2	
Typical Radiated Gain	0 dBi on azimuth plane	

	GSM 1800	GSM 1900
Frequency RX	1805 to 1880 MHz	1930 to 1990 MHz
Frequency TX	1710 to 1875 MHz	1850 to 910 MHz
RF Power Stand	1W at 12.5% duty cycle	1W at 12.5% duty cycle
Impedance	50 ohms	
VSWR	<2	
Typical Radiated Gain	0 dBi on azimuth plane	

Accessory Kit

A Wireless MultiModem Accessory Kit is available. Generally speaking, it is useful to have one or two kits to configure a group or fleet of Wireless MultiModem units (generally, you will not need one kit for every modem). The kit includes an antenna, a power supply and a product CD. The product CD contains an AT Command manuals, other documentation, and modem software.

AT Command Info

This manual describes a minimal set of AT commands that are adequate for configuring many common application situations. A complete set of AT command definitions can be found in the AT Command manuals (one for GSM/GPRS and one for CDMA). These manuals are available on the MultiTech web site or on the Accessory Kit CD.

Phone Number for the Wireless Modem

- Every wireless modem will have its own unique phone number.
- The wireless modem's phone number may simply be told to the subscriber or be on the SIM or both. Wireless provider implementations may vary.

Network Access

The network access arrangements to be specified in Windows Dial-Up Networking (of the computer that the wireless modem is serving) will vary according to the type of wireless service used.

- For GSM-without-GPRS, a circuit-switched data connection is used. The user can set up DUN to make a conventional V.32 modem connection to any terminating modem at the other end. The phone number specified in DUN can be one supplied by the wireless service provider or another phone number related to a different dialup modem service (e.g, a dialup modem service phone number from any commercial or private dialup network).
- For GSM-with-GPRS, a single DUN number is generally used by all of a wireless provider's subscribers throughout its area of coverage (regional, nationwide, continental, etc.). Rather than being a literal phone directory number, as in conventional DUN, this is a code that gives the modem Internet access.

Product Description

Features

<ul style="list-style-type: none">• GPRS Class 10 operation	<ul style="list-style-type: none">• V.42bis data compression
<ul style="list-style-type: none">• Dual-band 850/1900 or 900/1800 GSM/GPRS	<ul style="list-style-type: none">• Numerous LEDs provide operational status
<ul style="list-style-type: none">• GSM Class 1 and Class 2 Group 3 FAX	<ul style="list-style-type: none">• ME + SIM phone book management
<ul style="list-style-type: none">• Desktop or panel mounting	<ul style="list-style-type: none">• Fixed dialing number
<ul style="list-style-type: none">• Short Message Services including text and PDU, point-to-point, cell broadcast	<ul style="list-style-type: none">• SIM Toolkit Class 2
<ul style="list-style-type: none">• 14.4K GSM circuit switched data	<ul style="list-style-type: none">• SIM, network and service provider locks
<ul style="list-style-type: none">• SMA antenna connector and SIM socket	<ul style="list-style-type: none">• Real time clock
<ul style="list-style-type: none">• Serial interface supports DTE speeds to 115.2K	<ul style="list-style-type: none">• Alarm management
<ul style="list-style-type: none">• AT command compatible	<ul style="list-style-type: none">• UCS2 character set management

Application Overview

Application Types

With circuit switched data rates up to 14.4K bps, the MultiModem GSM/GPRS is targeted at applications that periodically need to send or receive data over a wireless network. It is an ideal solution for:

Appliances	Remote Diagnostics
ATM Terminals	Remote Metering
Automotive	Security Systems
Data Collection	Vending/Gaming Machines
Gas Pumps	Other devices requiring wireless connectivity.
Industrial and Medical Remote Monitoring Systems	Note: The Wireless MultiModem must be mounted with at least 8 inches (20 cm) of clearance from the human body.

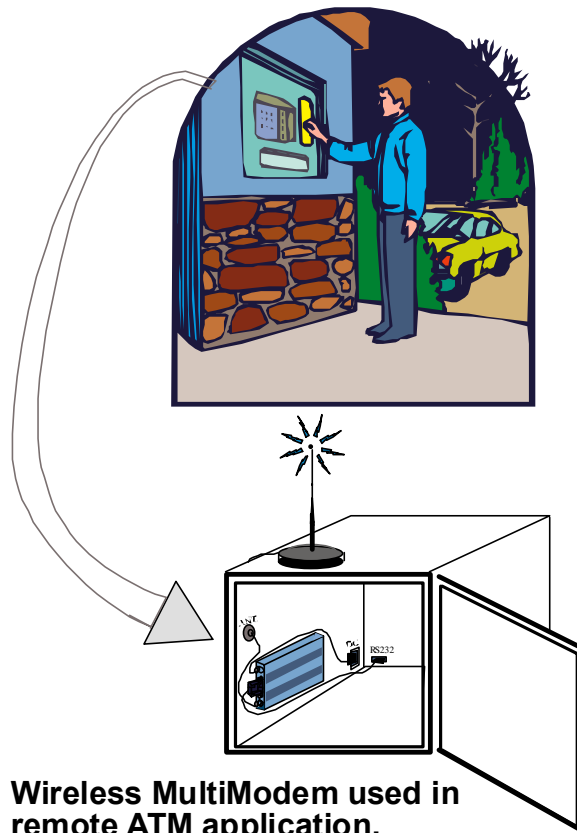

Wireless MultiModem used in remote ATM application.

Benefits/Features in Applications

Short Development Time. The MultiModem GSM/ GPRS can make your existing and next generation device, machine, or system, communication-ready without requiring any hardware changes to its design. It actually provides faster time-to-market because it relieves the burden and expense of obtaining network and RF approvals. This complete, ready-to-deploy wireless modem allows you to enhance your product while you focus on developing its core features.

Voice Features. The MultiModem GSM/GPRS provides telephony and Dual Tone Multi Frequency (DTMF) functionality. It also allows for emergency calls as well as echo cancellation and noise reduction (option), and full rate, enhanced Full Rate and Half Rate (FR/EFR/HR).

Short Message Services. The MultiModem GSM/GPRS offers SMS features such as text and PDU, point-to-point (MT/MO) and cell broadcast.

Compatible Supplementary Services. The MultiModem GSM/GPRS is compatible with supplementary services such as call forwarding, call barring, multiparty, call waiting and call hold, calling line identification, advice of charge, USSD, closed user group and explicit call transfer.

Management Features. The MultiModem GSM/GPRS provides advanced management features including phone book management, fixed dialing number, real time clock and alarm management.

Industry-standard Modem Commands. The MultiModem GSM/GPRS provides industry-standard AT-style commands for ease of integration into your existing software application.

Industrial Chassis. The MultiModem GSM/GPRS is packaged in a rugged, water resistant, industrial chassis. The chassis has an RS-232 DE-15 Voice/Data interface connector and a permanent screw-type power connector. It also has an SMA antenna connector. The chassis can be side-mounted on a panel or top-mounted on a desktop or other surface. A set of LEDs indicate the modem's operational status.

Network and RF Approved. The MultiModem GSM/ GPRS has been tested and certified with wireless telecom network providers worldwide. In addition, it has successfully completed worldwide compliance testing for global RF approval.

Functions – GSM Modes

MODE	DESCRIPTION
Standard	Dual Band Extended GSM 900 MHz Class 4 (2W) and GSM 1800/1900 MHz Class 1 (1W)
Interface	Serial interface RS232. V.24/V.28 Autobauding function. AT command set based on V.25ter and GSM 07.05 & 07.07
SMS	Mobile Originated (MO) and Mobile Terminated (MT) SMS Mode Text & PDU point to point. Cell broadcast in accordance with GSM 07.05.
Data	Asynchronous 2400, 4800, 9600 and 14400 bps. Data Transparent and Non Transparent modes. In Non Transparent Mode only: 300, 1200, 1200/75 baud rates are available. Mode 3.1 KHz (PSTN) and V110 (ISDN).
Fax	2400/4800/7200/9600 bps Fax GSM teleservice 62 in Transparent Mode. Class 2. Group 3 compatible.
GPRS	Class 10. Coding schemes: CS1 to CS4.

Specifications

General Specifications	
Power Requirements	5 V to 32VDC; 400mA Average @5V, 2A Peak @ 5V
Mechanical Dimensions & Weight	4.3" w x 2.4" h x 0.94" d; 4.1 oz. (11 cm x 6.1 cm x 2.4 cm; 115 g)
Connectors & Fasteners	<p>Antenna Connection type: SMA jack</p> <p>Serial Connector: 15-pin RS232 SUB D female (DE15S)</p> <p>Pins: RS232 link, audio link, BOOT, RESET</p> <p>Power Connector: 2.5mm miniature power jack</p> <p>SIM receptacle: (standard)</p>
Operating Temperatures	-30 to +60°C
Certifications	<p>CE Mark</p> <p>EMC: FCC Part 2, 15, 22, 24, EN 55022 & EN 55024</p> <p>Safety: UL 60950, EN 60950</p>

Specifications

Electrical Characteristics	
Switching the GSM modem on/off	The device is permanently powered (when connected to the power supply).
Voltage Range	Voltage range : 5 to 32V DC GND : 0V
Overvoltage and Undervoltage	Correct operation of the Wireless MultiModem in communication mode is not guaranteed if input voltage falls below 5V.

Input/output electrical characteristics for external connections

Parameters		GSM 850/900			GSM 1800/1900			Unit
		Min	Typ.	Max	Min	Typ	Max	
Power Supply @ 25 degrees C:								
- Input Supply Voltage		5	13.2	32	5	13.2	32	V
Input peak supply current (in comm. mode at Pmax)	@5V			1.8			1.1	A
	@13.2 V			0.7			0.4	A
	@32V			0.4			0.2	A
Input average supply current (in comm. mode at Pmax)	@5V			330			220	mA
	@13.2 V			130			95	mA
	@32V			65			50	mA

Specifications

Input/output electrical characteristics (cont'd)

Parameters	GSM 850/900			GSM 1800/1900			Unit
	Min	Typ.	Max	Min	Typ	Max	
Power Supply @ 25 degrees C:							
- Input Supply Voltage	5	13.2	32	5	13.2	32	V
Input average supply current in idle mode	@5V		31.4			31.4	mA
	@13.2 V		13.2			13.2	mA
	@32V		5.6			5.6	mA
SIM		3			3		V

LED Indicators	
TD. Transmit Data.	Lit when modem is transmitting data.
RD. Receive Data.	Lit when modem is receiving data.
CD. Carrier Detect.	Lit when data connection has been established.
LS. Line Status.	Continuous “on” state indicates that the wireless modem is not registered on the network. Flashing state indicates registration on network. Off state. Modem is off (not ready) or in download mode.
TR. Terminal Ready.	Commonly called “Data Terminal Ready.” This is a readiness signal from the PC.
PWR. Power.	Indicates presence of DC power when lit.

Specifications

RS232 15-Pin Connector Pinout

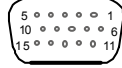

	PIN	EIA	CCIT	Designation
RS 232	1	DCD	109	Data Carrier Direct
	6	RX	104	Receive Data (out)
	2	TX	103	Transmit Data
	8	DTR	108.2	Data Terminal Ready
	9	GND		Signal Ground
	7	DSR	107	Data Set Ready
	12	RTS	105	Request to Send
	11	CTS	106	Clear to Send
	13	RI	125	Ring Indicator
Audio	4	MICROPHONE (+)		
	5	MICROPHONE (-)		
	10	SPEAKER (+)		
	15	SPEAKER (-)		
Boot	3	BOOT		
Reset	14	RESET		

Getting Started with your Wireless MultiModem

Mechanical Mounting

To mount the Wireless MultiModem, do the following:

1. Obtain mounting screws (two are needed) that are appropriate for the surface on which you will mount the MultiModem. The mounting screw on the connector end of the unit must have a screw-head no thicker than 2 mm. The allowable thickness is limited because the screw must fit beneath the RS232 cable. The allowable thickness of the other screw-head is not limited in this way.

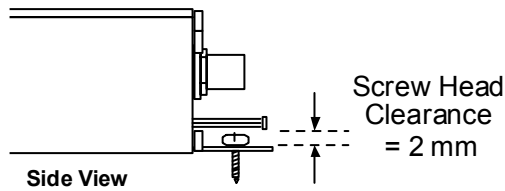

Getting Started

For example, one might use two 6-32 self-tapping screws 5/8" in length to mount the unit in a truck to the wall of the cab behind the passenger's seat.

- Typically, the unit is mounted against a flat surface into which holes can be drilled. The mounting holes (center-to-center) must be separated by 125mm or 4 -15/16 inches.

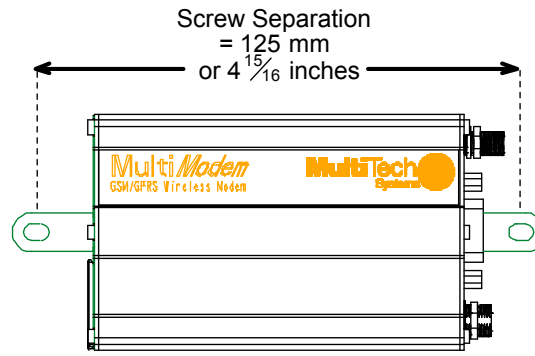

Drill the mounting holes at the desired mounting location (if applicable).

3. Slide the mounting bridles into the corresponding slots on the back side of the MultiModem chassis.

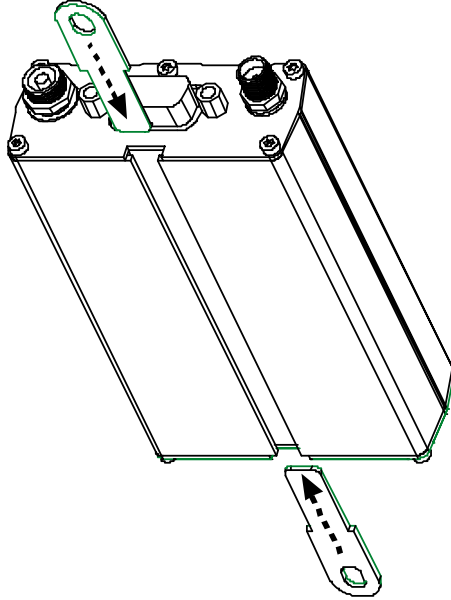

4. Attach the MultiModem with two screws to the mounting surface at the desired location on the equipment.

Electrical Installation & Configuration

The wireless MultiModem requires the power supply connection to begin operation. It also requires a SIM card (Subscriber Identity Module) to operate on a GSM network. To install the modem, do the following:

1. Using your fingernail or a small wedging tool (e.g., a small screwdriver), pry off the SIM cover.

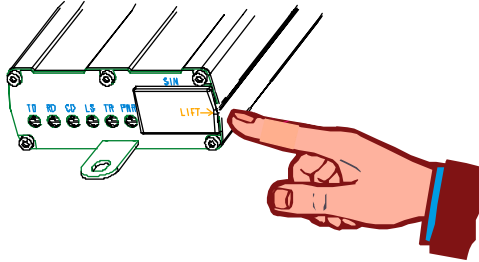

2. Insert the SIM card into the holder.

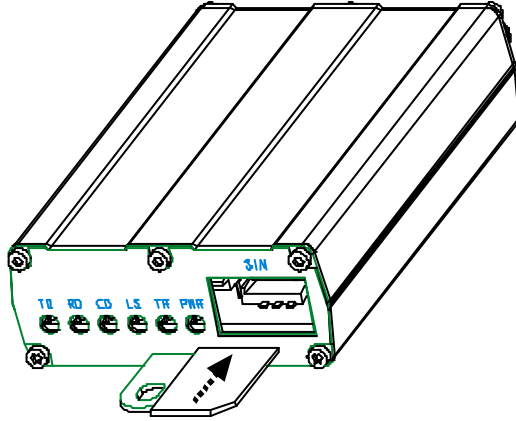

Getting Started

3. Verify that the SIM card fits into the holder properly and then replace the cover.

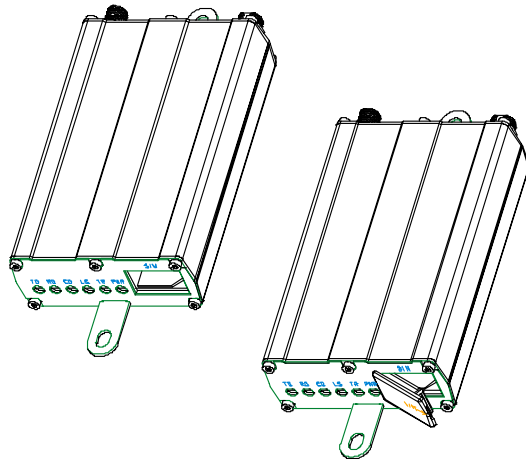

4. Connect a suitable antenna to the SMA connector (see specifications on page 8).

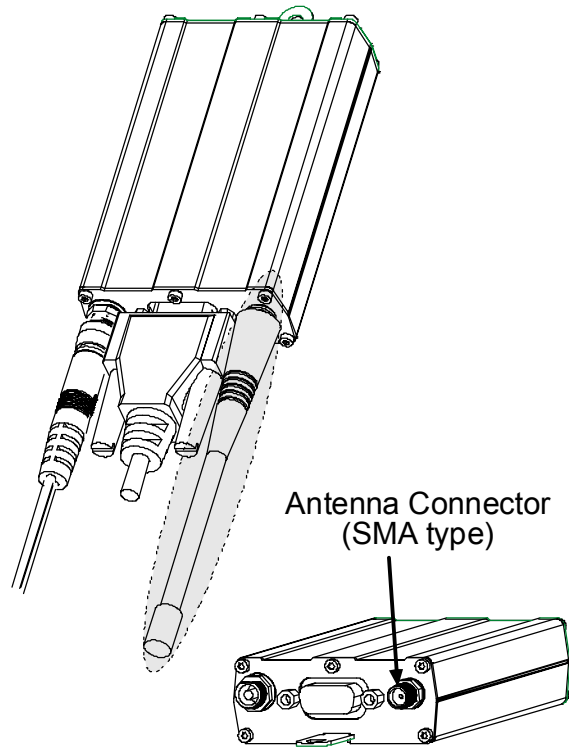

Getting Started

5. Connect both sides of the serial and control cable (15-pin Sub D connector on the modem side).

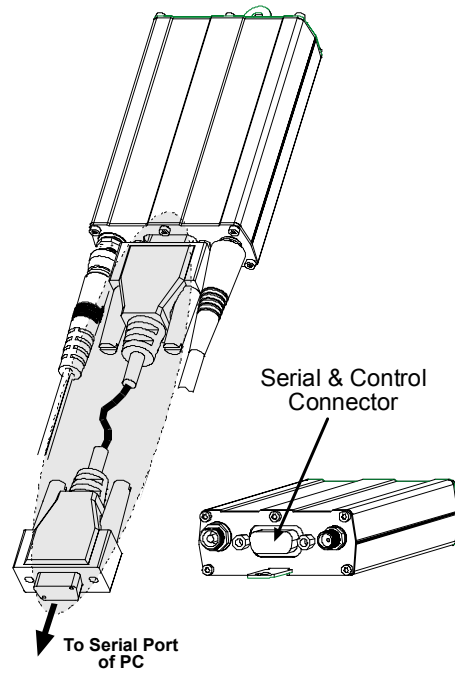

6. Plug the power supply cable into the wireless Multimodem.

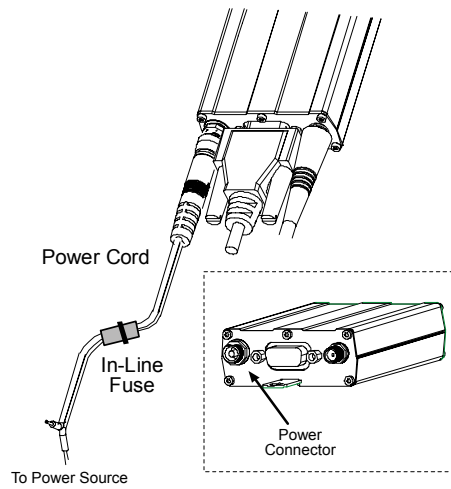

7. Connect the power supply cable into the power supply, with a correct GND connection. Connect red wire to + (positive) and black wire to – (negative).

Note: For automotive application: according to the type of application, you can use permanent “+” or key-switched “+”.

Getting Started

Connect the power supply to its source (for example, in a mobile situation, to the vehicle's DC fuse/terminal block).

8. Activate the power supply.

Mobile Phonetools

For initial configuration of your wireless device, Multi-Tech offers a Windows® based mobile Phone Tools application.

To load mobile Phone Tools, click on the mobile Phone Tools icon on your system CD and follow the on screen prompts.

Verifying signal strength

The Wireless MultiModem establishes a call if the signal is sufficiently strong. To verify the signal strength, do the following:

1. Using the **Hyperterminal** program at the computer to which the Wireless MultiModem is connected, type the AT command AT+CSQ. A value for the received signal strength will be returned.
2. Verify the result with the following chart:

Signal Strength Verification	
Value of signal strength (AT+CSQ response) (RSSI)	Signal strength
11 - 31	sufficient*
0 - 10	insufficient*
greater than 99	insufficient*
*Based on general observations.	

Verifying network registration

In this procedure, you will verify that the Wireless MultiModem has been registered on the wireless network. To do so, you will use the common communications program **Hyperterminal**.

1. Using the **Hyperterminal** program at the computer to which the Wireless MultiModem is connected, type the AT command **AT+CREG?**. A value for the modem's network registration status will be returned.
2. Verify the result with the following chart:

Network Registration Verification	
Value	Network Registration Status
0, 1	Yes
0, 5	Yes (registered roaming)

Note: If the modem is not registered, perform the procedure for **Verifying signal strength** on page 38 to determine the strength of the received signal.

Testing the Configuration

Descrip- tion	AT Commands	Response Returned	Comments
Enter PIN Code	AT+CPIN =1234	OK	PIN Code accepted
		+CME ERROR : 16	Incorrect PIN Code
		+CME ERROR : 3	PIN already entered (with +CMEE : 1 mode)
Module synchro checking	AT + CREG ?	CREG = <mode>, 1	modem synchronized on the network
		CREG = <mode>, 2	synchronization lost, re-synchronization attempt
		CREG = <mode>, 0	Modem not synchronized on network. No synchronization attempt

Testing the Configuration (continued)

Descrip- tion	AT Commands	Response Returned	Comments
Receiving an incoming call		RING	
	ATA		Answer the call.
		OK	
Initiate a call	ATD1234;		Don't forget the ";" at the end for "voice" calls.
		OK	Communication established
		CME ERROR : 11	PIN Code not entered (with +CMEE : 1 mode)
		CME ERROR : 3	AOC credit (Advice of Charge tells the user how much a call will cost) has been exceeded or a communication is already established.

Testing the Configuration (continued)

Descrip- tion	AT Commands	Response Returned	Comments
Initiate an emergency call	ATD112;	OK	Don't forget the ";" at the end for "voice" calls.
Communi- cation loss		NO CARRIER	
Hang up	ATH		
		OK	
Store the parameters in non- volatile memory	AT&W		
		OK	The communications program has saved the configuration settings in non- volatile memory.

Troubleshooting

Situation A: The modem does not answer through the serial link

If the Wireless MultiModem does not answer through the serial link upon an attempted transmission of data or voice signals, see the table below for possible causes and solutions.

Solutions for 'no connection through serial link' situation		
If the modem returns ...	Then ask ...	Action
(nothing)	Is the modem powered correctly?	Provide a power supply in the range of 5 to 32Vdc.
	Is the serial cable properly connected to the modem and PC sockets?	Connect cable per step 5 of the "Electrical Installation and Configuration" procedure on page 33. Verify cable pinout per "RS232 15-Pin Connector Pinout" table, esp Rx & Tx connections. Verify reception & transmission.

Solutions for 'no connection through serial link' situation (cont'd)		
If the modem returns ...	Then ask ...	Action
(nothing) <i>{cont'd}</i>	Is the communication program properly configured?	In communications program, verify that modem parameters have been set to the values shown here: Data Bits = 8 Parity = none Stop Bits = 1 Baud = 115200 bps
	Is another program interfering with the communication program?	Close any such application program.

Situation B: The modem always returns «Error» when trying to issue a communication

If the Wireless MultiModem returns a message of error upon an attempted transmission of data or voice signals, see the table below for possible causes and solutions.

Solutions for “error” message situations		
If the modem returns ...	Then ask ...	Action
error	Is the modem registered on the network?	Follow “Verifying network registration” procedure to be sure modem is registered on network.
	Is the modem receiving an incoming call or is it already in communication?	End any communication using the ATH command.
	Does AT+CREG? return 0,1 (registered) or 0,5 (registered roaming)?	If not, check for adequate signal strength on network. Use AT+CSQ.

Solutions for “error” message situations (cont’d)		
If the modem returns ...	Then ask ...	Action
error <i>(cont’d)</i>	<p>Is the selected bearer type supported by the called party?</p> <p>Is the selected bearer type supported by the network?</p>	<p>In comm. program, type AT+CMEE=1 to view the extended error codes (see “Interpretation ...” table below). Retry.</p> <p>Be sure called party and network support selected bearer type.</p> <p>Be sure that semi-colon (“;”) is typed immediately after the phone number in the AT command. E.g., ATD#####;</p>
	Is the received signal strong enough?	See “Signal Strength Verification,” p 38.
	Is the antenna properly connected?	See “Antenna Specifications,” page 8.

Interpretation of Extended Error Codes related to "error" message		
Error Code	Diagnostic	Hint
0	Phone failure	Call technical support
3	Operation not allowed	No action.
4	Operation not supported	No action.
10	SIM not inserted	Do one of the following: Insert the SIM card into the modem's SIM holder. Be sure SIM card is clean & properly inserted in holder.
11	SIM PIN required	Enter PIN code.
12	SIM PUK required	Enter PUK code. Note: Call your network provider if you do not know this code.
13	SIM failure	Check validity of your SIM card. If SIM damaged, call your network provider.
16	Incorrect password	Check the code you entered.

Interpretation of Extended Error Codes related to “error” message (cont’d)		
Error Code	Diagnostic	Hint
17	SIM PIN2 required	Enter PIN2 code.
18	SIM PUK2 required	Enter PUK2 code. Note: Call your network provider if you do not know this code.
26	Dialing string too long	Check the phone number (max. 20 digits).
30	No network service	No action.
32	Network not allowed – emergency calls only	No action.
40	Network personalization PIN required (Network lock)	Enter the Network lock. Note: Call your network provider if you do not know this code.
103	Illegal MS (#3)	No action.
106	Illegal MS (#6)	No action.
107	GPRS services not allowed (#7).	Contact your network provider to subscribe to GPRS service.
111	PLMN not allowed (#11)	No action.

Troubleshooting

Interpretation of Extended Error Codes related to “error” message (cont’d)		
Error Code	Diagnostic	Hint
112	Location area not allowed (#13)	No action.
113	Roaming not allowed in this location area (#13)	No action.
132	Service option not supported (#32).	Check the service option.
133	Requested service option not subscribed (#33)	Call your network provider to subscribe to the requested service option.
134	Service option temporarily out of order (#34)	No action.
148	Unspecified GPRS error	No action.
149	PDP authentication failure	Call your network provider to subscribe to the requested service option.
150	Invalid mobile class	Change to valid class.

For all other codes, and/or details, see AT Commands manual.

Situation C: The modem always returns «No carrier» when trying to issue a communication

Solutions for “no carrier” message		
If the modem returns ...	Then ask ...	Action
no carrier <i>(esp. for data communication)</i>	<p>Is the selected bearer type supported by the called party?</p> <p>Is the selected bearer type supported by the network?</p>	<p>Type AT+CEER to view the extended error code (see “Interpretation of Extended Error Codes” table, page 52). Be sure that the selected bearer type is supported by the called party.</p> <p>Be sure that the selected bearer type is supported by the network.</p> <p>If no success, try bearer selection type: AT+CBST=0,0,3 Be sure SIM card is available for data/fax calls.</p>

Solutions for “no carrier” message (cont'd)		
If the modem returns	Then ask ...	Action
no carrier <i>(esp. for voice communication)</i>		Be sure that the semicolon character (“;”) is typed immediately after the phone number in the AT command. E.g., ATD#####; type AT+CBST=0,0,3 Configure the SIM card for data/fax calls.
	Is the received signal strong enough?	See “Signal Strength Verification,” page 38.
	Is the antenna properly connected?	See “Antenna Specifications,” page 8.

Interpretation of Extended Error Codes related to "no carrier" message		
Error Code	Diagnostic	Hint
1	Unallocated phone number	Not allocated
16	Normal call clearing	
17	User busy	
18	No user responding	
19	User alerting, no answer	
21	Call rejected	
22	Number changed	
31	Normal, unspecified	

Troubleshooting

Interpretation of Extended Error Codes related to “no carrier” message (cont'd)		
Error Code	Diagnostic	Hint
50	Requested facility not subscribed	Check your subscription (data subscription available?)
68	ACM equal or greater than ACM Max	Credit of your pre-paid SIM card expired?
252	Call barring on outgoing calls	Not applicable
253	Call barring on outgoing calls	Not applicable
3, 6, 8, 29, 34, 38, 41, 42, 43, 44, 47, 49, 57, 58, 63, 65, 69, 70, 79, 254	Network causes	Call network provider See AT commands manual for further details.

For all other codes, and/or details, see AT commands manual.

Further troubleshooting information will be presented on the (searchable) MultiTech web site as such information becomes available.

Safety

General Safety

The modem is designed for and intended to be used in fixed and mobile applications. “Fixed” means that the device is physically secured at one location and is not able to be easily moved to another location. “Mobile” means that the device is designed to be used in other than fixed locations and generally in such a way that a separation distance of at least 20 cm (8 inches) is normally maintained between the transmitter’s antenna and the body of the user or nearby persons. The Modem is not designed for or intended to be used in portable applications (within 20 cm. or 8 in. of the body of the user) and such uses are strictly prohibited.

Safety

It is important to follow any special regulations regarding the use of radio equipment due in particular to the possibility of radio frequency, RF, interference. Please follow the safety advice given below carefully.

- Switch OFF your Wireless MultiModem when in an aircraft. The use of cellular telephones in an aircraft may endanger the operation of the aircraft, disrupt the cellular network and is illegal. Failure to observe this instruction may lead to suspension or denial of cellular telephone services to the offender, or legal action or both.
- Switch OFF your Wireless MultiModem when around gasoline or diesel-fuel pumps and before filling your vehicle with fuel.
- Switch OFF your Wireless MultiModem in hospitals and any other place where medical equipment may be in use.
- Respect restrictions on the use of radio equipment in fuel depots, chemical plants or where blasting operations are in progress.
- There may be a hazard associated with the operation of your Wireless MultiModem close to inadequately protected personal medical devices such as hearing aids and pacemakers. Consult the manufacturers of the medical device to determine if it is adequately protected.
- Operation of your Wireless MultiModem close to other electronic equipment may also cause interference if the equipment is inadequately protected. Observe any warning signs and manufacturers' recommendations.

Vehicle Safety

- Do not use your Wireless MultiModem while driving, unless equipped with a correctly installed vehicle kit allowing 'Hands-Free' Operation.
- Respect national regulations on the use of cellular telephones in vehicles. Road safety always comes first.
- If incorrectly installed in a vehicle, the operation of Wireless MultiModem telephone could interfere with the correct functioning of vehicle electronics. To avoid such problems, be sure that the installation has been performed by qualified personnel. Verification of the protection of vehicle electronics should be part of the installation.
- The use of an alert device to operate a vehicle's lights or horn on public roads is not permitted.

Maintenance of GSM Modem

Your Wireless MultiModem is the product of advanced engineering, design and craftsmanship and should be treated with care. The suggestions below will help you to enjoy this product for many years.

- Do not expose the Wireless MultiModem to any extreme environment where the temperature or humidity is high.
- Do not attempt to disassemble the Wireless MultiModem. There are no user serviceable parts inside.

Safety

- Do not expose the Wireless MultiModem to water, rain or spilt beverages. It is not waterproof.
- Do not abuse your Wireless MultiModem by dropping, knocking, or violently shaking it. Rough handling can damage it.
- Do not place the Wireless MultiModem alongside computer discs, credit or travel cards, or other magnetic media. The information contained on discs or cards may be affected by the phone.
- The use of accessories not authorized by MultiTech or not compliant with MultiTech's accessory specifications may invalidate the warranty of the Wireless MultiModem.
- In the unlikely event of a fault in the Wireless MultiModem, contact MultiTech Tech Support.

Your Responsibility

This Wireless MultiModem is your responsibility. Please treat it with care respecting all local regulations. It is not a toy. Therefore, keep it in a safe place at all times and out of the reach of children.

Try to remember your Unlock and PIN codes. Become familiar with and use the security features to block unauthorized use and theft.

Warranty & Repairs Policies

Warranty

Multi-Tech Systems, Inc., (hereafter "MTS") warrants that its products will be free from defects in material or workmanship for a period of two years from date of purchase, or if proof of purchase is not provided, two from date of shipment.

MTS MAKES NO OTHER WARRANTY, EXPRESS OR IMPLIED, AND ALL IMPLIED WARRANTIES OF MERCHANTABILITY AND FITNESS FOR A PARTICULAR PURPOSE ARE HEREBY DISCLAIMED.

This warranty does not apply to any products which have been damaged by lightning storms, water, or power surges or which have been neglected, altered, abused, used for a purpose other than the one for which they were manufactured, repaired by Customer or any party without MTS's written authorization, or used in any manner inconsistent with MTS's instructions.

MTS's entire obligation under this warranty shall be limited (at MTS's option) to repair or replacement of any products which prove to be defective within the warranty period or, at MTS's option, issuance of a refund of the purchase price. Defective products must be returned by Customer to MTS's factory – transportation prepaid.

Warranty & Repair

MTS WILL NOT BE LIABLE FOR CONSEQUENTIAL DAMAGES, AND UNDER NO CIRCUMSTANCES WILL ITS LIABILITY EXCEED THE PRICE FOR DEFECTIVE PRODUCTS.

Repairs

Repair Procedures for U.S. and Canadian Customers

In the event that service is required, products may be shipped, freight prepaid, to our Mounds View, Minnesota factory:

Multi-Tech Systems, Inc.
2205 Woodale Drive
Mounds View, MN 55112
Attn: Repairs, Serial # _____

A Returned Materials Authorization (RMA) is not required. Return shipping charges (surface) will be paid by MTS.

Please include, inside the shipping box, a description of the problem, a return shipping address (must have street address, not P.O. Box), your telephone number, and if the product is out of warranty, a check or purchase order for repair charges.

For out of warranty repair charges, go to
www.multitech.com/documents/warranties

Extended two-year overnight replacement service agreements are available for selected products. Please call MTS at (888) 288-5470, extension 5308 or visit our web site at <http://www.multitech.com/programs/orc/> for details on rates and coverage's.

Please direct your questions regarding technical matters, product configuration, verification that the product is defective, etc., to our Technical Support department at (800) 972-2439 or email tsupport@multitech.com. Please direct your questions regarding repair expediting, receiving, shipping, billing, etc., to our Repair Accounting department at (800) 328-9717 or (763) 717-5631, or email mtsrepair@multitech.com.

Repairs for damages caused by lightning storms, water, power surges, incorrect installation, physical abuse, or user-caused damages are billed on a time-plus-materials basis.

Repair Procedures for International Customers (Outside U.S.A. and Canada)

Your original point of purchase Reseller may offer the quickest and most economical repair option for your Multi-Tech product. You may also contact any Multi-Tech sales office for information about the nearest distributor or other repair service for your Multi-Tech product.

<http://www.multitech.com/COMPANY/offices/DEFAULT.ASP>

In the event that factory service is required, products may be shipped, freight prepaid to our Mounds View, Minnesota factory. Recommended international shipment methods are via Federal Express, UPS or DHL courier services, or by airmail parcel post; shipments made by any other method will be refused. A Returned Materials Authorization (RMA) is required for products shipped from outside the U.S.A. and Canada. Please contact us for return authorization and shipping instructions on any International shipments to the U.S.A. Please include, inside the shipping box, a description of the problem, a return shipping address (must have street address, not P.O. Box), your telephone number, and if the product is out of warranty, a check drawn on a U.S. bank or your company's purchase order for repair charges. Repaired units shall be shipped freight collect, unless other arrangements are made in advance.

Please direct your questions regarding technical matters, product configuration, verification that the product is defective, etc., to our Technical Support department nearest you or email tsupport@multitech.com. When calling the U.S., please direct your questions regarding repair expediting, receiving, shipping, billing, etc., to our Repair Accounting department at +(763) 717-5631 in the U.S.A., or email mtsrepair@multitech.com.

Repairs for damages caused by lightning storms, water, power surges, incorrect installation, physical abuse, or user-caused damages are billed on a time-plus-materials basis.

Repair Procedures for International Distributors

Procedures for International Distributors of Multi-Tech products are on the distributor web site.
<http://www.multitech.com/PARTNERS/login/>

Wireless Modem Reference Info

GSM reference documents : GSM 03.40, GSM 03.45, GSM 04.11,
GSM 04.21, GSM 05.08, GSM 07.01,
GSM 07.02, GSM 07.05, GSM 07.07.

ETSI contact : ETSI Secretariat
F-06921 Sophia Antipolis Cedex,
France
e-mail : secretariat@etsi.fr

Service : The AT commands manual is available
on the MultiTech web site:
<http://www.multitech.com>

Disclaimer

Wireless MultiModem specifications and manuals are subject to change without notice. MTS assumes no liability for damage incurred directly or indirectly from errors, omissions or discrepancies between the Wireless MultiModem and its manuals.



82001220
